



ATC60

MULTI-TIER REACH-IN

PLANT GROWTH

DATA SHEET

ATC60 REACH-IN

ARABIDOPSIS



Product Overview/ Applications

The ATC60 provides an unprecedented growth-area-to-footprint ratio. It uses a top-mounted refrigeration system that accommodates servicing from the front of the chamber, and that simplifies on-site installation. The ATC60 offers three tiers with almost 60 ft² (5.57 m²) of growth area in a 25 ft² (2.32 m²) footprint. With a growth height of 21 inches above each shelf, the ATC60 is ideally suited for Arabidopsis and other short to medium height plants. Standard on the ATC60 is a flood tray at each tier to simplify plant irrigation. Please consult Conviron regarding specific requirements.

Lighting

The standard lighting package for the ATC60 combines T5 fluorescent and halogen incandescent lamps which produces a very broad based light spectrum of low-to-medium light intensity. Heat from the two lamp canopies is removed by the refrigeration system. The lamps are separated from the growth area by a transparent barrier which minimizes heat transfer to the plants. Standard light intensity is 500 micromoles/m²/s which is measured by a quantum light meter and transmitted to the controller for user readout. Lighting is switched in three levels for each lamp type.

Airflow

Airflow is distributed horizontally via a perforated back wall plenum across each shelf. This helps to establish uniform air distribution and a consistent temperature gradient around the growth area that is independent of plant loading. The unit includes a fresh air intake and exhaust which is adjustable to allow up to 20 ft³/min (0.57m³/min.) of air exchange.

Refrigeration System

Cooling for the ATC60 is provided by a top-mounted, water-cooled condensing unit with a hot-gas bypass system for continuous compressor operation. An electronic modulating valve provides tight temperature control while ensuring quiet operation. Pressure transducers are included for monitoring the status of the refrigeration system. Consult the factory for heat rejection information and other options for cooling.

Experiment Protecting

User programmable "set and forget" alarms track the chamber's operation versus user-defined set points. This allows for exceptionally accurate monitoring without the need for adjustment every time the set point is redefined. Backup "high/low" alarms provide a further level of protection while visual and audible notification is provided when any alarm is activated. Contacts for connection to a building management system are also included.

Key Product Attributes

- Unprecedented growth-area-to-footprint ratio
- Three shelves each with 20" (510mm) growth height
- Lamp canopies separated from growth space by a transparent barrier to minimize heat transfer
- Top-mounted machine compartment minimizes footprint, accommodates serviceability, and simplifies installation
- Growth area drain pans double as irrigation trays for convenient mass watering of plants
- Product certifications/markings; _cCSA_{US} (NRTL), CE



Performance Data

Temperature Range (°C)	Interior Capacity	Growth Area	Growth Height	Exterior Dimensions (WxDxH)	Light Intensities (6in. from lamp)	Electrical Service	Weight
10 – 40 lights ON	103ft ³	57ft ²	20"	100" x 35.5" x 101"	500 μmoles/m ² /s	120/208-3Ø-60Hz	1900lb.
4 – 40 lights OFF	(2915l)	(5.2m ²)	(510mm)	2540 x 900 x 2565 (mm)	@ 25°C	220/380-3Ø-50Hz	(860kg)

CONVIRON MODEL ATC60

ARABIDOPSIS CHAMBER



NOTES:

1. STANDARD REFRIGERATION SYSTEM IS WATER COOLED, (1/2"Ø (13mmØ) CONNECTION).
2. CHAMBER MUST BE SECURELY FASTENED TO FLOOR.
3. DEPTH DIMENSION IS CHAMBER SIZE ONLY. DIMENSION DOES NOT INCLUDE DOOR LATCH OR HINGES.
4. FOR BACK TO BACK INSTALLATION, ALLOW 2" (50mm) SPACE BETWEEN CHAMBERS.
5. LENGTH AND WIDTH DIMENSIONS ±1/4" (6mm), HEIGHT DIMENSION ±1" (25mm). DO NOT SCALE DRAWING.

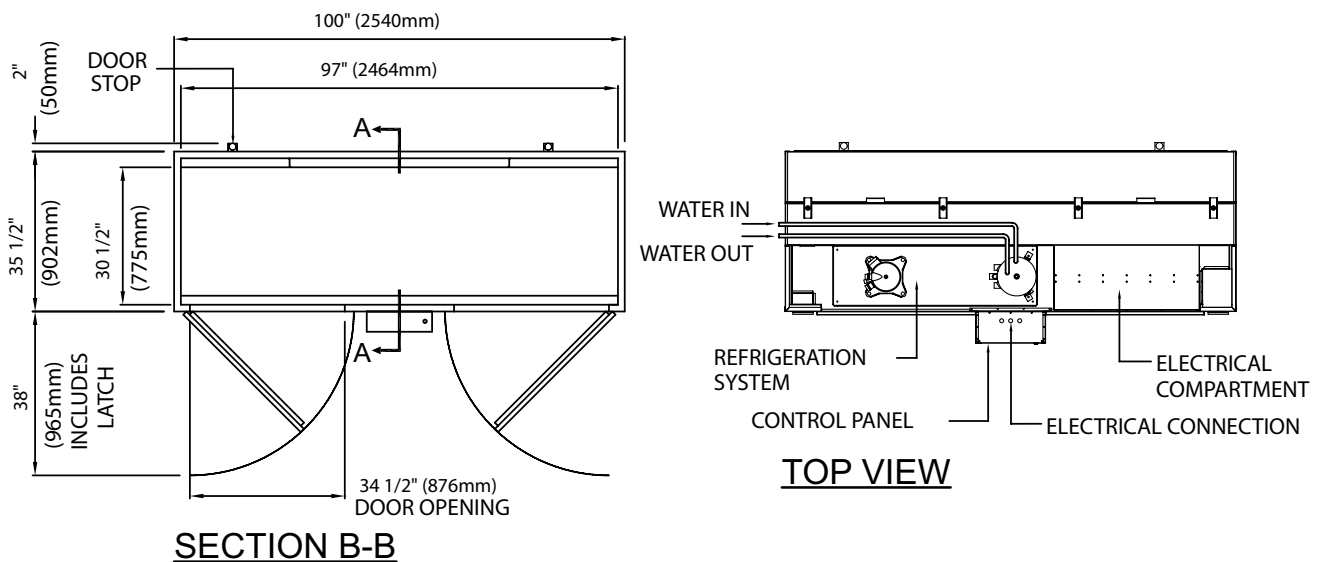
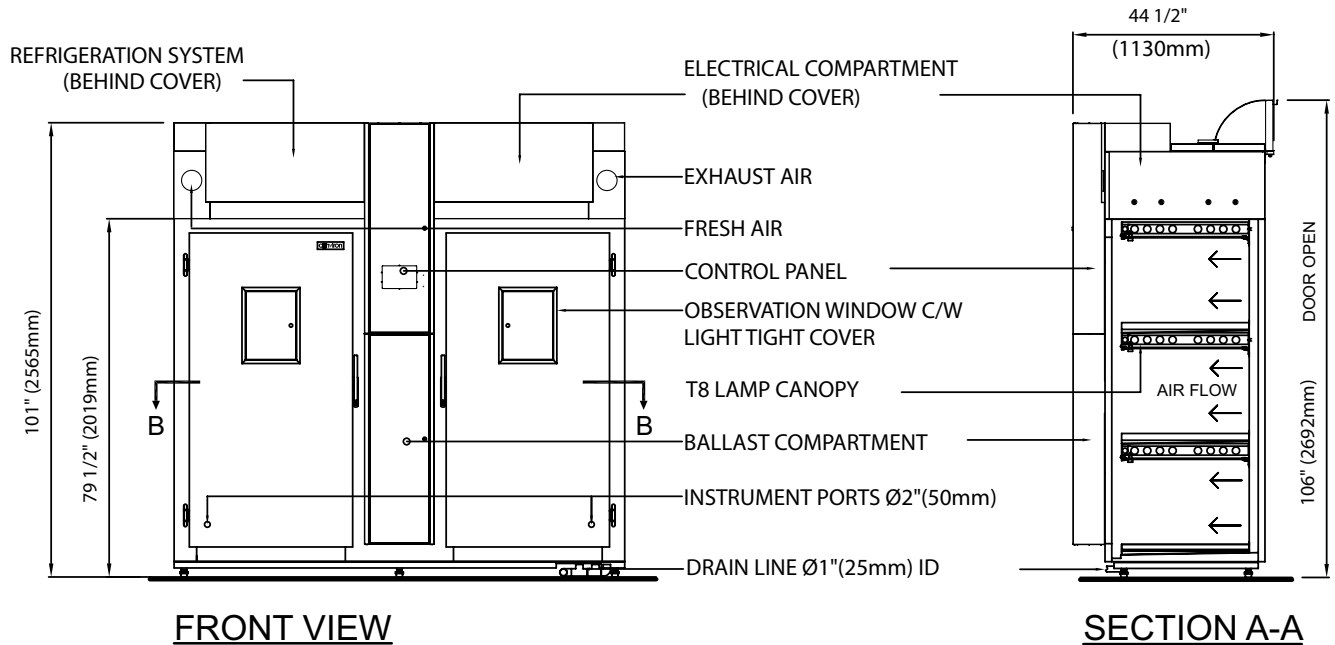

AT60 GROWTH CHAMBER

DATE ISSUED: 07/14/09

DRAWING NO. 231150

